



HANSON RIVET

& SUPPLY CO.

13241 Weidner Street
Pacoima, CA 91331

Phone: 818-485-0500

FAX: 818-485-0540

Outside CA: 1-800-RRRIVET

www.hansonrivet.com



AUTO FEED - RIVET MACHINES



These are our most popular machines.
Perfect for economical,
trouble free-riveting



Heavy duty work horse riveters.
They are the most modern
riveters available.

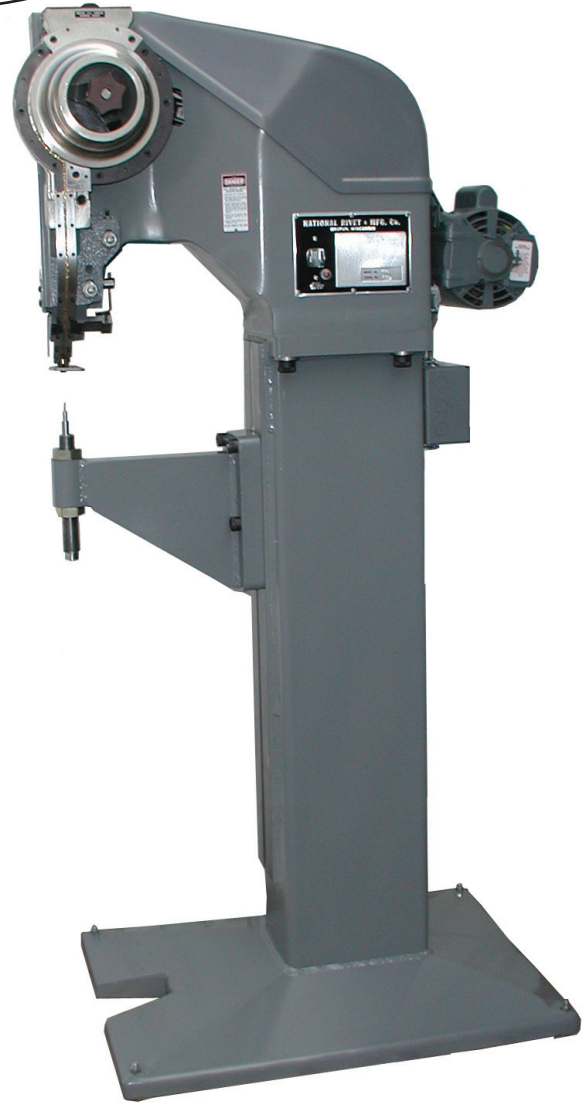
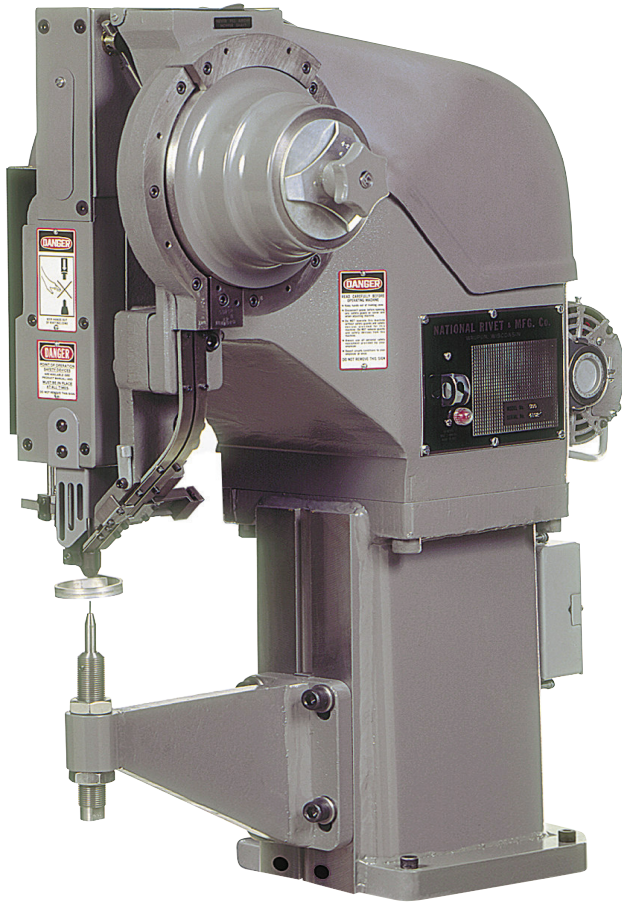

MODEL	TUBULAR STEEL RIVET CAPACITY	LENGTH CAPACITY	THROAT DEPTH	MODEL	TUBULAR STEEL RIVET CAPACITY	LENGTH CAPACITY	THROAT DEPTH
500B Bench 500BA Air	5/32"	3/4"	10"	600	3/16"	STANDARD: 1-3/8"	12"
	5/32"	3/4"	10"	616	3/16"		16"
500 Floor 500A Air	5/32"	3/4"	10"	625	3/16"	SPECIAL: UP TO 2-1/2"	25"
	5/32"	3/4"	10"	800	1/4"		12"
				816	1/4"		16"
				1000	5/16"		12"
				1200	3/8"		12"
				3000	1/2"		12"
				3160	1/2"		12"

OUR RIVETERS ARE EQUIPPED WITH "QUICK CHANGE HOPPERS" FOR PRODUCTION VERSATILITY.

ASK ABOUT OUR RENTAL PROGRAMS!

Please visit www.hansonrivet.com/autofeed.htm to view video.



HANSON RIVET

& SUPPLY CO.

13241 Weidner Street
Pacoima, CA 91331

Phone: 818-485-0500

FAX: 818-485-0540

Outside CA: 1-800-RRRIVET

www.hansonrivet.com



AUTO FEED - RIVET MACHINES



Designed to handle miniature rivets.

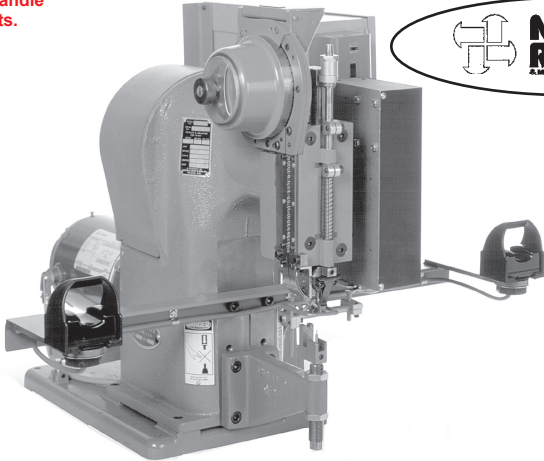

NATIONAL RIVET
A MANUFACTURING CO.

Multiple head installations on a common base is the main advantage of these models.



MODEL	TUBULAR STEEL RIVET CAPACITY	LENGTH CAPACITY	THROAT DEPTH	MODEL	TUBULAR STEEL RIVET CAPACITY	LENGTH CAPACITY	THROAT DEPTH
B BA Air	.028-.125"	3/8"	6"	1500	1/8"	5/8"	10"
	.028-.125"	3/8"	6"	1500F Floor	1/8"	5/8"	10"
				1600	3/16"	3/4"	12"
				1600F Floor	3/16"	3/4"	12"
				1600-Offset	3/16"	3/4"	14"
				1600F-Offset	3/16"	3/4"	14"

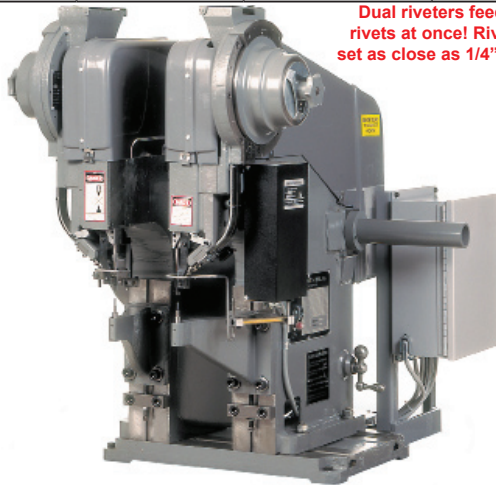

Dual riveters feed and set 2 rivets at once! Rivets can be set as close as 1/4" on center.

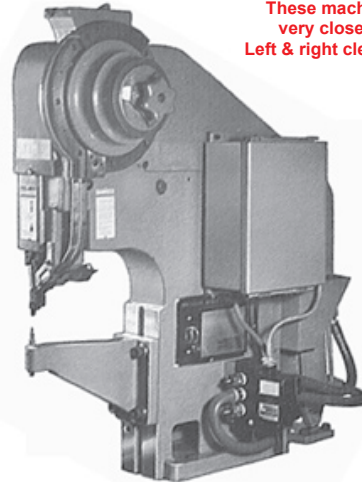

These machines will set rivets very close to vertical angles. Left & right clearances available.

MODEL	TUBULAR STEEL RIVET CAPACITY	LENGTH CAPACITY	THROAT DEPTH	MODEL	TUBULAR STEEL RIVET CAPACITY	LENGTH CAPACITY	THROAT DEPTH
2400B	1/8"	5/8"	8"	2410BA L.H.	1/8"	3/4"	8"
2400F	1/8"	5/8"	8"	2420BA R.H.	1/8"	3/4"	8"
2400BA	1/8"	3/4"	8"	2410FA L.H.	1/8"	3/4"	8"
2400FA	1/8"	3/4"	8"	2420FA R.H.	1/8"	3/4"	8"
2600B	3/16"	5/8"	8"	2610BA L.H.	3/16"	3/4"	8"
2600F	3/16"	5/8"	8"	2620BA R.H.	3/16"	3/4"	8"
2600BA	3/16"	3/4"	8"	2610FA L.H.	3/16"	3/4"	8"
2600FA	3/16"	3/4"	8"	2620FA R.H.	3/16"	3/4"	8"
2614	3/16"	3/4"	14"				
2850	1/4"	1"	10"				

OUR RIVETERS ARE EQUIPPED WITH "QUICK CHANGE HOPPERS" FOR PRODUCTION VERSATILITY.

ASK ABOUT OUR RENTAL PROGRAMS!

Please visit www.hansonrivet.com/autofeed.htm to view video.

D85